

RL 737 Mini-flood

The Reeflite RL 737 mini-flood fibreglass luminaire range consists of white fibreglass housings, and is manufactured using the following materials:

- A rigged orthophthalic unsaturated polyester resin, white pigmented and UV stabilised, that complies with SABS 713-1999 standard.
- 450 Grams per square meter (Continuous strand length) fibreglass matt for improved strength, flexibility and good heat dissipation.
- White external protective paint layer for increased UV protection.

The luminaire is fitted with a specular, smooth aluminium reflector, shaped asymmetrically in the vertical plane. The lamp holder is secured into a 30% glass filled Nylon Fix lamp holder assembly that is secured onto the side of the housing.

	<p>RL737 FLOODLIGHT 70(1) HPS - 80 MV - 125 MV</p>	 60598-2-5
	<p>DESCRIPTION</p>	
<p>APPLICATIONS</p> <ul style="list-style-type: none"> ■ SECURITY ■ PERIMETERS ■ SIGNAGE ■ SMALL HOLDINGS ■ PARKS AND GARDENS 	<ul style="list-style-type: none"> ■ corrosion resistant glass reinforced polyester housing ■ heat tempered glass ■ integral control gear ■ compact ■ high purity aluminium reflector ■ galvanised mounting stirrup 	
<p>ORDERING DATA</p>		

code	corrected line current		weight
	starting	running	
RL737 - 70 (I) HPS	0.72 A	0.45 A	3.44 KG
RL737 - 80 MV	0.90 A	0.45 A	2.74 KG
RL737 - 125 MV	1.35 A	0.68 A	3.14 KG



RL737 226 FLOODLIGHT

2 x 26 W PL



DESCRIPTION

- corrosion resistant glass reinforced polyester housing
- heat tempered glass
- integral control gear
- compact
- high purity aluminium reflector
- galvanised mounting stirrup

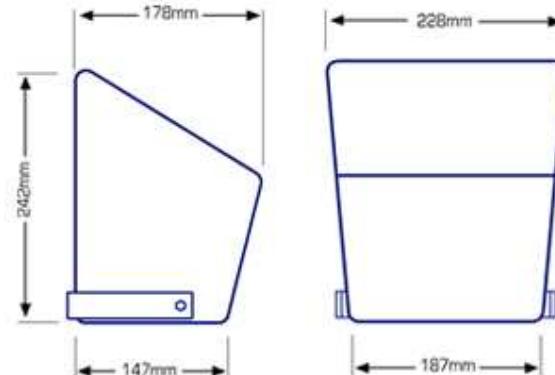

APPLICATIONS

- SECURITY
- PERIMETERS
- SIGNAGE
- GARDENS

ORDERING DATA

code	lamp type	weight
RL737 226	2 x 26 W PL	2.78 KG

For excellent durability in all types of whether conditions, the stirrup bracket is manufactured from electroplated mild steel. This standard bracket system can be used in wall mount applications. A pole mount clamp is available to clamp a pole diameter up to 76mm. All internal gear plates and support structures inside the luminaire are electroplated to ensure excellent durability.

The fitting is guaranteed for life (15 Years) against deterioration due to ultra-violet radiation, hail damage and corrosion at coastal areas.