

LED LuxPanel Ø240mm



- Remote “plug and play” style driver, supplied in standard, dimmable or emergency options
- Maintenance free panel
- Epistar LED and Tridonic Driver
- Edgelit White Frame

[Click here for more information](#)



LUCECO

The luminaire contains built-in LED lamps.

The lamps cannot be changed in the luminaire.

874/2012

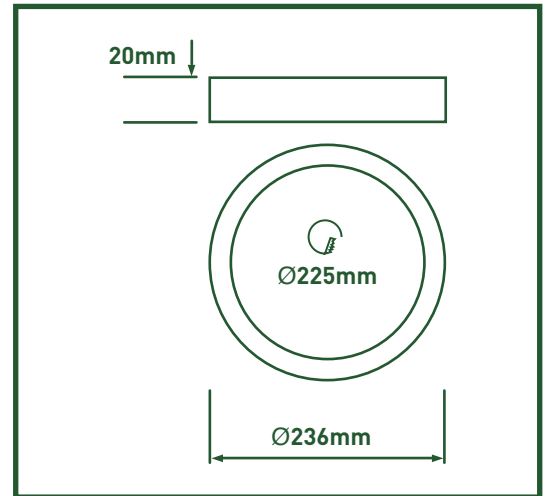

5 years extended (3 years standard) guarantee and 1 year onsite warranty available in the UK. Rest of the world may vary, please ask your local distributor for more information.



(6000k available colour temperature, subject to minimum order requirements)



RoHS



Cat No.	Description	Voltage	Barcode
LP240WS48	Standard driver	230V	5015056530413
LP240WD48	Dimmable driver	230V	5015056530437
LED3EP80	Emergency pack	-	5015056532240

- Driver current = 350mA



Standards

EN 60598-1	Luminaires - General requirements	EN 61000-3-2	Electromagnetic compatibility (EMC) - Part 3-2: Limits - Limits for harmonic current emissions
EN 60598-2-2	Luminaires - Recessed	EN 62471	Photobiological safety of lamps and lamp systems
EN 61347-1	Lamp controlgear - Part 1: General and safety requirements	2002/96/EC	Waste Electrical & Electronic Equipment (WEEE)
EN 61347-2-13	Lamp controlgear - Part 2-13 : Particular requirements for d.c. or a.c. supplied electronic controlgear for LED modules	2011/65/EU	Restriction of the use of certain Hazardous Substances in EEE (RoHS)
EN 55015	Limits and methods of measurement of radio disturbance characteristics of electrical lighting and similar equipment	(EC) No 1907/2006	The Registration, Evaluation, Authorisation and Restriction of Chemicals (REACH)
EN 61547	Equipment for general lighting purposes - EMC immunity requirements		

Tech Help Line

UK - **0845 194 7584**

Non UK - **+44 (0)1952 238 100**

Supplied by

BG Electrical Ltd

Stafford Park 1 TF3 3BD ENGLAND

Visit our website at

www.luceco.uk